

HC-PD

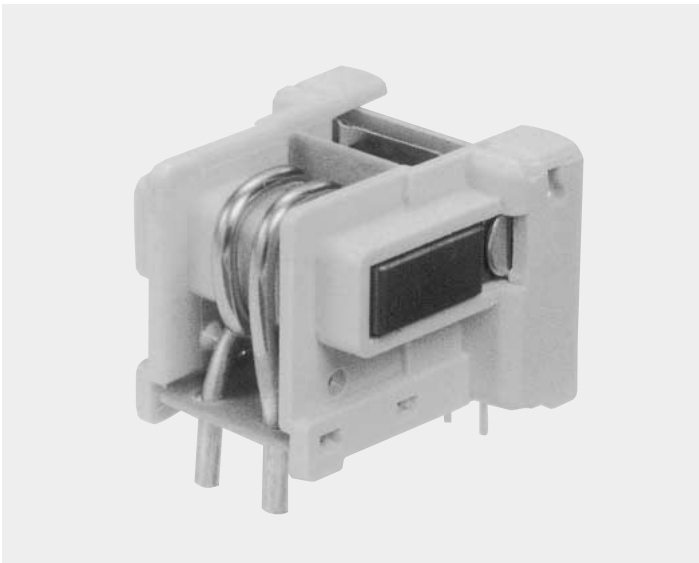

- Rated current5A~50A
- Reduced height compact design

Applications

Inverters, servo drivers, NC machine tools

Dimensions

(mm)

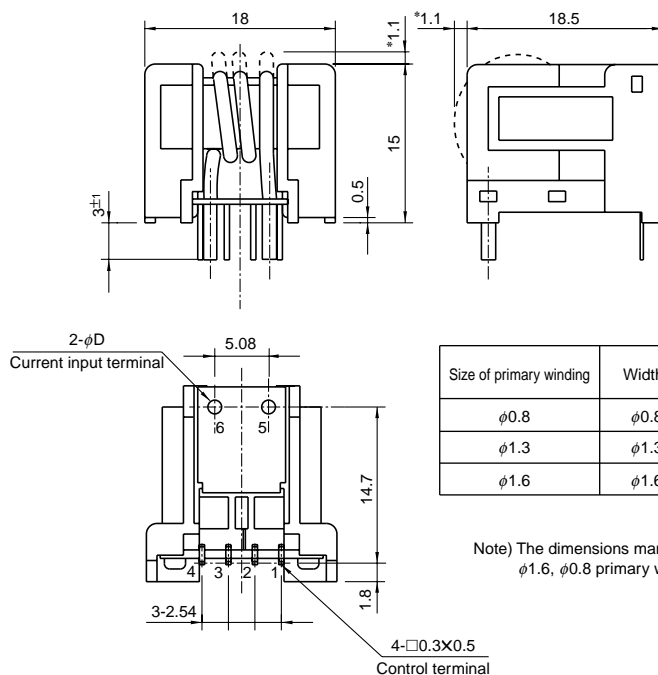

Size of primary winding	Width D
φ0.8	φ0.8
φ1.3	φ1.3
φ1.6	φ1.6

- Terminal No.
- 1...(-) terminal
 - 2...GND
 - 3...(+ terminal
 - 4...Output
 - 5...(+ input
 - 6...(-) input

Weight : 6g

Note) The dimensions marked with * apply only for the φ1.6, φ0.8 primary winding

Specification

Ta=25°C

Type	HC-PD05V4B15	HC-PD10V4B15	HC-PD20V4B15	HC-PD30V4B15	HC-PD50V4B15
Rated current [If]	±5A	±10A	±20A	±30A	±50A
Saturation current [Is]	±15A	±30A	±45A	±90A	±90A
Linearity limits	0~±12.5A	0~±25A	0~±37.5A	0~±75A	0~±75A
Size of primary winding	φ0.8	φ1.3	φ1.3	φ1.6	φ1.6
Rated output [Vh]	±4V±2% (RL=10kΩ)				
Residual output [Vo]	Within ±100mV				
Output linearity	Within ±1%				
Response time	Within 10μs (at di/dt=If/μs)				
Output Temp. Coef.	Within ±0.1%/°C				
Residual output Temp. Coef.	Within ±6mV/°C				
Control power supply	±15V±5%				
Operating Temp.	-10°C~+75°C				
Storage Temp.	-15°C~+85°C				
Dielectric withstand voltage	2500V AC 50/60Hz 1minute				
Insulation resistance	Not less than 500MΩ 500V DC				

Note1) The indicated residual voltage is the one after the core hysteresis is removed.

Note2) For continuously flowing DC currents, see the principal characteristics marked by an asterisk (*) on page 1-5.

Characteristics chart

HC-PD05V4B15

Time base : 5μs/div.

Pulse current response characteristic

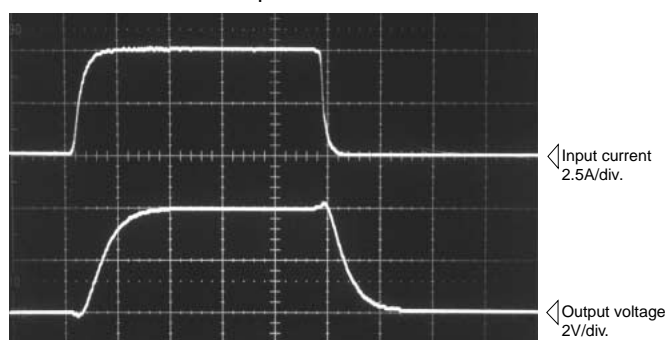

Noise characteristics (Effects of dv/dt)

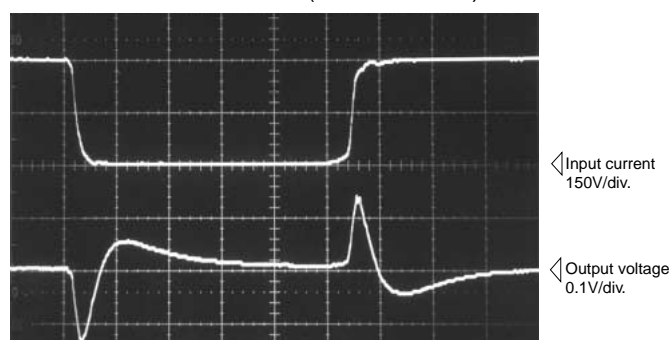

Noise characteristics (Effects of impulse noise)

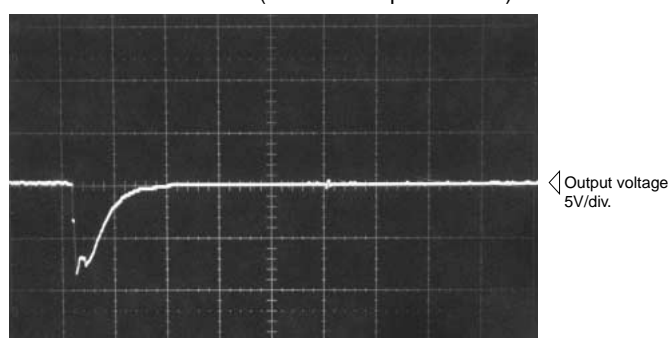

Input/output characteristics

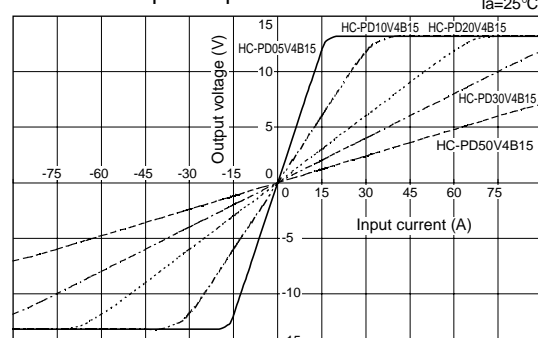

Note : The mark "◁" means 0V or 0A.