

HC-W



- Rated current .....50A~300A
- Superior noise-resistance and temperature characteristics
- Two circuits can be measured at the same time

Applications

Inverters, power supply equipment, NC machine tools

Dimensions

(mm)

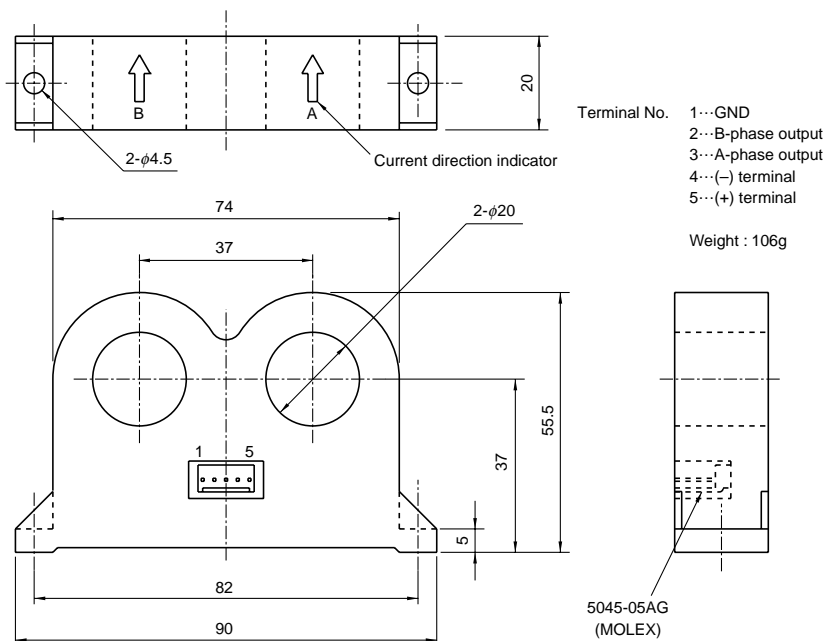

## Specification

Ta=25°C

Type	HC-W050V4B15	HC-W100V4B15	HC-W300V4B15
Rated current [If]	±50A	±100A	±300A
Saturation current [Is]	±150A	±300A	±700A
Linearity limits	0~±150A	0~±300A	0~±600A
Rated output [Vh]	±4V±1%		
Residual output [Vo]	Within ±30mV		
Output linearity	Within ±1%		
Response time	Within 10μs (at di/dt=100A/μs)		
Output Temp. Coef.	Within ±0.08%/°C		
Residual output Temp. Coef.	Within ±1.5mV/°C		
Control power supply	±15V±5%		
Operating Temp.	-10°C~+75°C		
Storage Temp.	-15°C~+85°C		
Dielectric withstand voltage	2500V AC 50/60Hz 1minute		
Insulation resistance	Not less than 500MΩ 500V DC		

Note1) The indicated rated output is the one when no load is applied.

Note2) The indicated residual voltage is the one after the core hysteresis is removed.

## Characteristics chart

HC-W100V4B15

Time base : 5μs/div.

Pulse current response characteristic

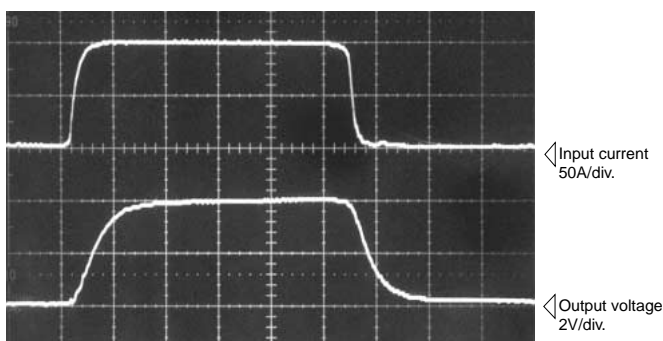

Noise characteristics (Effects of dv/dt)

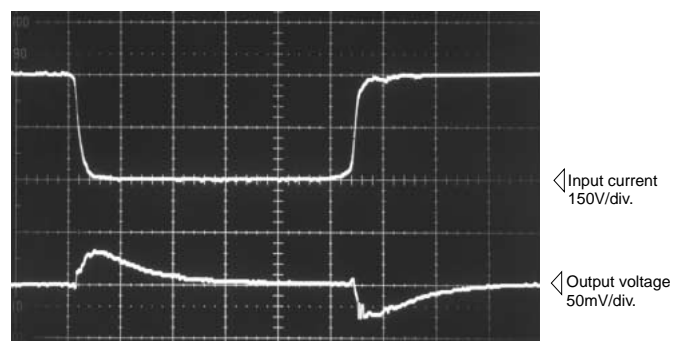

Noise characteristics (Effects of impulse noise)

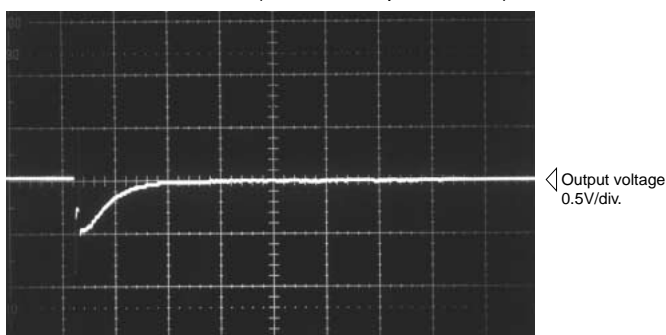

Input/output characteristics

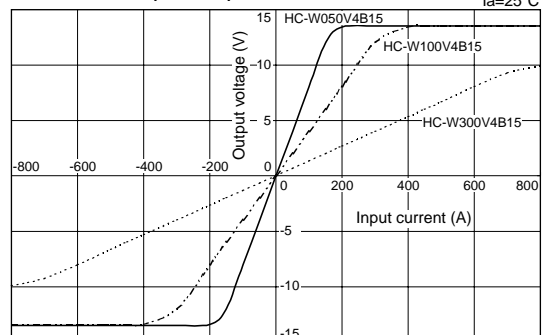

Note : The mark "◁" means 0V or 0A.