

HS-UD



- Rated current 300A ~ 500A
- Superior in response, linearity and temperature characteristics
- Both the voltage output and the current output were prepared

Applications

Inverters, servo drivers, power supply equipment, NC machine tools

Dimensions

(mm)

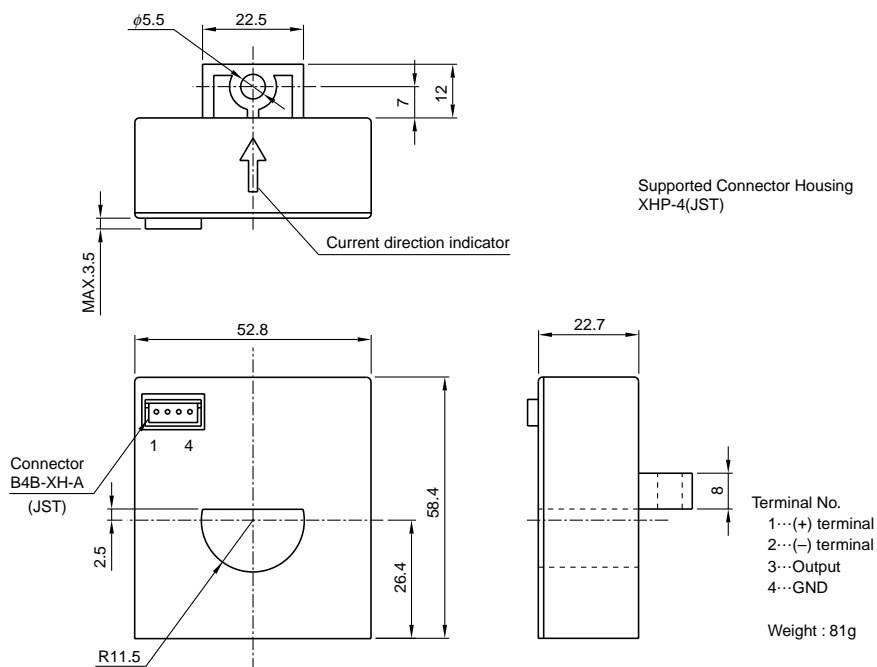

Specification

Ta=25°C

Type	Voltage output type			Current output type		
	HS-UD300V4B15	HS-UD400V4B15	HS-UD500V4B15	HS-UD300A015B15	HS-UD400A020B15	HS-UD500A025B15
Rated current [If]	±300A	±400A	±500A	±300A	±400A	±500A
Continuously flowing DC current	±450A	±450A	±450A	±450A	±450A	±450A
Saturation current [Is]	±900A	±1200A	±1200A	±800A	±1000A	±1200A
Linearity limits	0~±900A	0~±1200A	0~±1200A	0~±800A(RL=10Ω)	0~±1000A(RL=5Ω)	0~±1200A(RL=1Ω)
Rated output [Vh]	±4V±1% (RL=10kΩ)			±150mA±1%	±200mA±1%	±250mA±1%
Residual output [Vo]	Within ±20mV			Within ±0.2mV		
Output linearity	Within ±0.5%			Within ±0.5%		
Response time	Within 1μs (The smaller one on either at di/dt = 100 A/μs or If/μs.)			Within 1μs (The smaller one on either at di/dt = 100 A/μs or If/μs.)		
Response performance	Within 10%			Within 10%		
Hysteresis voltage range	Within 20mV			Within 0.2mA		
Output Temp. Coef.	Within ±0.02%/°C			Within ±0.02%/°C		
Residual output Temp. Coef.	Within ±1mV/°C			Within ±0.01mA/°C		
Control power supply	±15V±5%					
Consumption current	20mA+(Input current/2000)					
Operating Temp.	-10°C~+75°C					
Storage Temp.	-15°C~+85°C					
Dielectric withstand voltage	2500V AC 50/60Hz 1minute					
Insulation resistance	Not less than 500MΩ 500V DC					

Note1) The indicated residual voltage is the one after the core hysteresis is removed.

2) Energization time of saturation current shall be within 1 second.

3) Energization time of continuous live DC current ×150% shall be within 1 minute.

Characteristics chart

HS-UD500V4B15G

Time base : 5μs/div.

Pulse current response characteristic

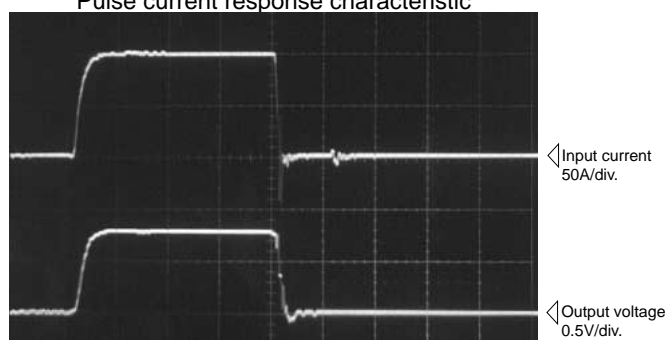

Noise characteristics (Effects of dv/dt)

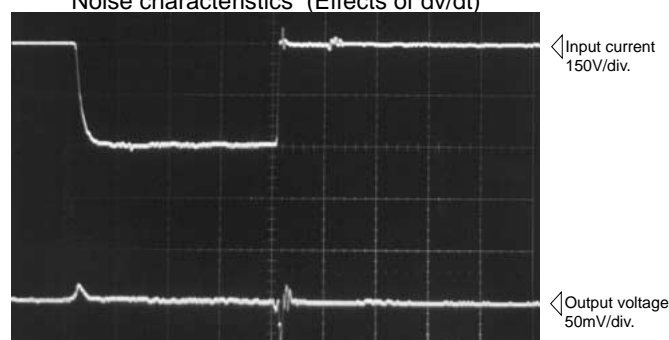

Noise characteristics (Effects of impulse noise)

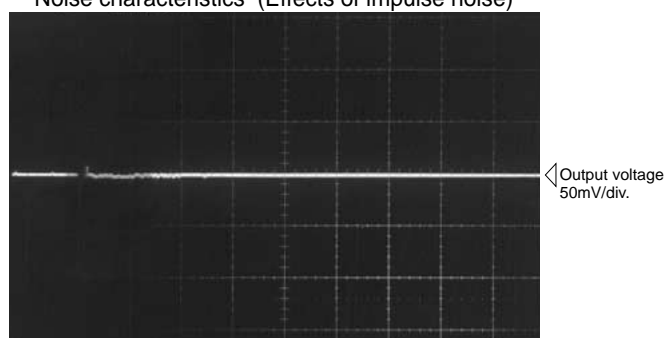

Load resistance-output characteristics (Current output type) Ta=25°C

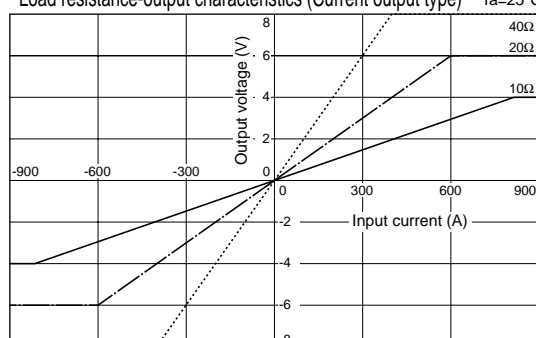

Note : The mark "◁" means 0V or 0A.